

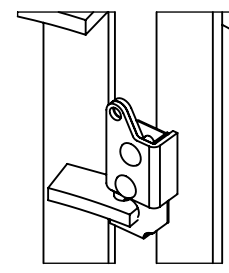

1240 North Van Buren Street - Suite 207  
 Anaheim, California 92807 info@dmbranco.com  
 www.dmbranco.com  
 714-674-0855

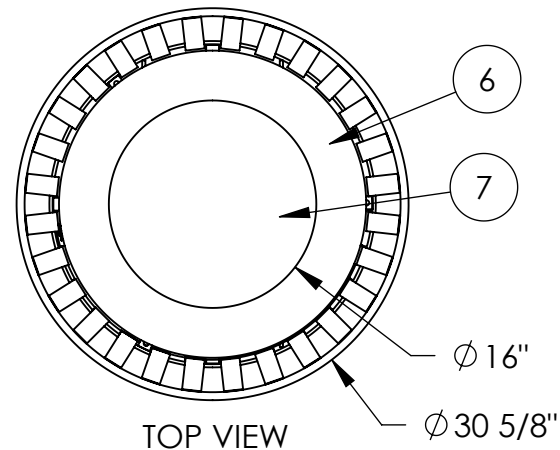
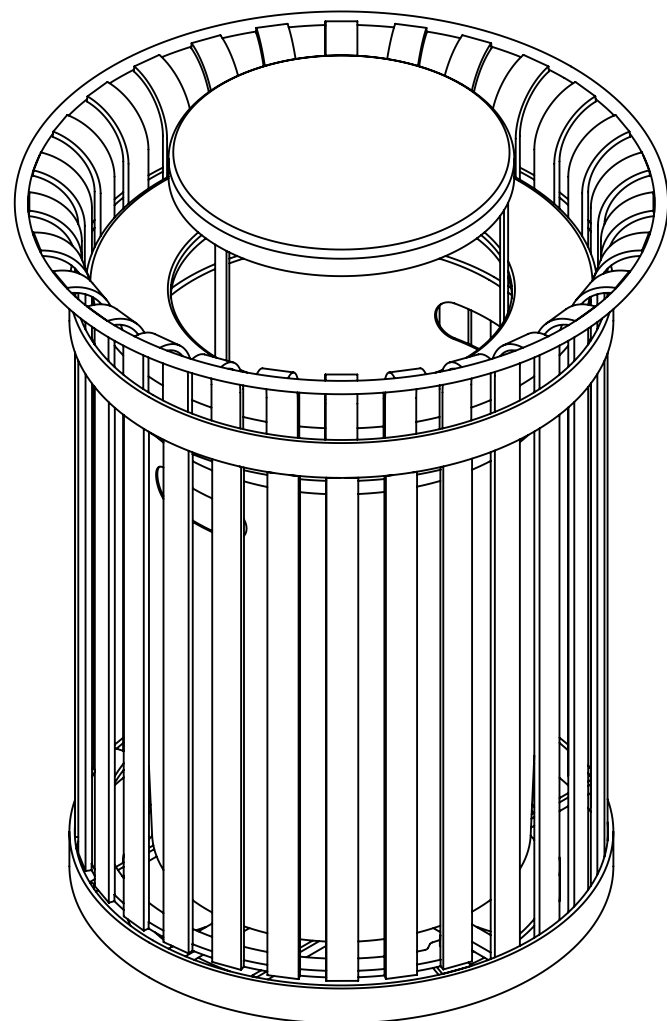

Materials List

- (1) Vertical Straps - 5/16" x 1 1/2" Steel Flat Bar
- (2) Top Ring -  $\phi$  5/8" Steel Round Bar
- (3) Support Rings - 1/4" x 2" Steel Flat Bar
- (4) Support Bars - 1/2" x 1" Steel Flat Bar
- (5) Surface Mount Plates - 1/4" x 1 1/2" Stainless Steel Plate with 9/16" Mounting Hole
- (6) Lid -  $\phi$  24" x .075" Wall Steel Lid
- (7) Dome -  $\phi$  16" x .105" Wall Steel Dome
- (8) Hinged Door With Stainless Steel Latch
- (9) Mounted with Three  $\phi$  1/2" x 4-5" Stainless Steel Anchor Bolts (Customer Supplied)
- (10) 36 Gallon Rigid Plastic Liner with Handles Included

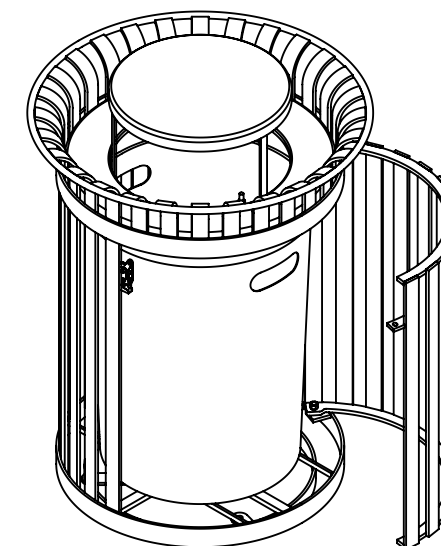
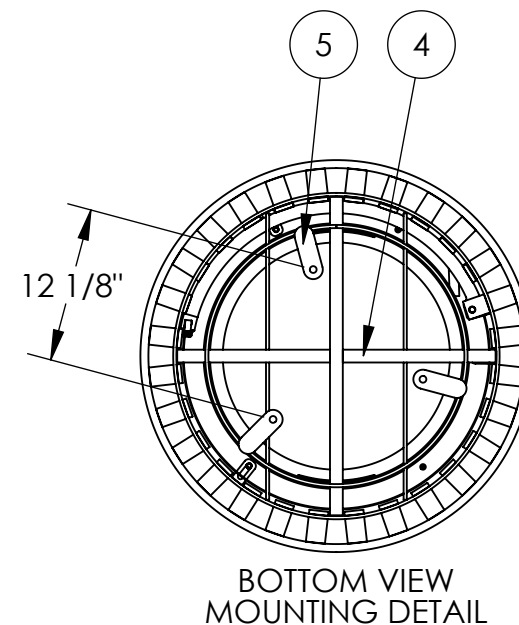
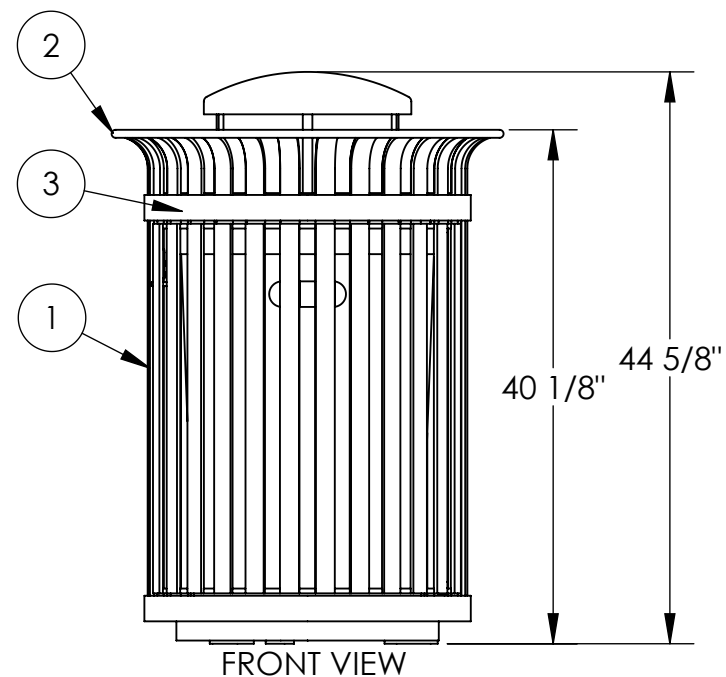

COMMENTS: INCH TOLERANCES U.O.S. FRACTION--±1/16" ANG-----±1°		 1240 North Van Buren Street - Suite 207 Anaheim, California 92807 info@dmbranco.com www.dmbranco.com	
		Project Name: AVENUE ONE-36 GAL DOME LID	
DWG. Name:		SIZE: DWG. NO.	REV.
THE INFORMATION CONTAINED IN THIS DRAWING IS THE SOLE PROPERTY OF D.M.BRAUN. ANY REPRODUCTION IN PART OR AS A WHOLE WITHOUT THE WRITTEN PERMISSION OF D.M.BRAUN IS PROHIBITED.		WEIGHT:	SHEET 1 OF 1

PROPRIETARY AND CONFIDENTIAL

THE INFORMATION CONTAINED IN THIS DRAWING IS THE SOLE PROPERTY OF D.M.BRAUN. ANY REPRODUCTION IN PART OR AS A WHOLE WITHOUT THE WRITTEN PERMISSION OF D.M.BRAUN IS PROHIBITED.

AVE-LR002-DL